

# Fast Recovery Diode

## M1242NC260 to M1242NC360

The data sheet on the subsequent pages of this document is a scanned copy of existing data for this product.  
(Rating Report 85NR2 Issue 1)

This data reflects the old part number for this product which is: **SM26-36CXC824**. This part number must **NOT** be used for ordering purposes – please use the ordering particulars detailed below.

Please use the following link to view an up to date outline drawing for this device  
[Outline W5](#)

Where any information on the product matrix page differs from that in the following data, the product matrix must be considered correct

An electronic data sheet for this product is presently in preparation.

For further information on this product, please contact your local ASM or distributor.

Alternatively, please contact Westcode as detailed below.

<b>Ordering Particulars</b>			
M1242	NC	◆◆	0
Fixed Type Code	Fixed Outline Code	Voltage code $V_{DRM}/100$ 26-36	Fixed Code
Typical Order Code: M1242NC260, 27.7mm clamp height, 2600V $V_{RRM}$			

**IXYS Semiconductor GmbH**  
Edisonstraße 15  
D-68623 Lampertheim  
Tel: +49 6206 503-0  
Fax: +49 6206 503-627  
E-mail: [marcom@ixys.de](mailto:marcom@ixys.de)

**WESTCODE**  
An IXYS Company

**Westcode Semiconductors Ltd**  
Langley Park Way, Langley Park,  
Chippenham, Wiltshire, SN15 1GE.  
Tel: +44 (0)1249 444524  
Fax: +44 (0)1249 659448  
E-mail: [WSL.sales@westcode.com](mailto:WSL.sales@westcode.com)

**IXYS Corporation**  
3540 Bassett Street  
Santa Clara CA 95054 USA  
Tel: +1 (408) 982 0700  
Fax: +1 (408) 496 0670  
E-mail: [sales@ixys.net](mailto:sales@ixys.net)

[www.westcode.com](http://www.westcode.com)

[www.ixys.com](http://www.ixys.com)

**Westcode Semiconductors Inc**  
3270 Cherry Avenue  
Long Beach CA 90807 USA  
Tel: +1 (562) 595 6971  
Fax: +1 (562) 595 8182  
E-mail: [WSI.sales@westcode.com](mailto:WSI.sales@westcode.com)

The information contained herein is confidential and is protected by Copyright. The information may not be used or disclosed except with the written permission of and in the manner permitted by the proprietors Westcode Semiconductors Ltd.

© Westcode Semiconductors Ltd.

In the interest of product improvement, Westcode reserves the right to change specifications at any time without prior notice.

Devices with a suffix code (2-letter, 3-letter or letter/digit/letter combination) added to their generic code are not necessarily subject to the conditions and limits contained in this report.

# QUALITY AND EVALUATION LABORATORY

Rating Report No: 85NR2 Issue 1

Date: 5th July 1996

Origin: Q.E.L.

Pages: 22

## Diode Capsule Type : SM26-36CXC824

Written by: M Baker

Checked: *Abdul Chen*Approved: *Bliff*

This diode consists of a diffused 50 mm diameter silicon slice, reference FFMFC, mounted in a cold weld capsule.

### Ratings

Voltage Grades ) A blocking voltage derating factor	: 26 - 36
) of 0.13% per deg. Celsius is applicable	
V <sub>RSM</sub> ) to this device for T <sub>J</sub> below 25 <sup>0</sup> C	: 2700 - 3700 V
)	
V <sub>R<sub>RRM</sub></sub> )	: 2600 - 3600 V
I <sub>F(AV)</sub> : Single phase: 50 Hz, 180 <sup>0</sup> half sinewave;	
Double Side Cooled T <sub>HS</sub> = 55 <sup>0</sup> C, 100 <sup>0</sup> C	: 1243 A, 600 A
Single Side Cooled T <sub>HS</sub> = 100 <sup>0</sup> C	: 348 A
I <sub>F(rms)</sub> T <sub>HS</sub> = 25 <sup>0</sup> C )	: 2465 A
) Double side cooled	
I <sub>F</sub> T <sub>HS</sub> = 25 <sup>0</sup> C )	: 2108 A
I <sub>FSM</sub> : t = 10ms half sinewave; T <sub>J</sub> (initial) = 125 <sup>0</sup> C V <sub>RM</sub> = 0.6V <sub>R<sub>RRM</sub></sub> (MAX)	: 16.4 kA
I <sub>FSM</sub> : t = 10ms half sinewave; T <sub>J</sub> (initial) = 125 <sup>0</sup> C V <sub>RM</sub> ≤ 10V	: 18.0 kA
I <sup>2</sup> t : t = 10ms; T <sub>J</sub> (initial) = 125 <sup>0</sup> C; V <sub>RM</sub> = 0.6V <sub>R<sub>RRM</sub></sub> (MAX)	: 1.34 x 10 <sup>6</sup> A <sup>2</sup> s
I <sup>2</sup> t : t = 10ms; T <sub>J</sub> (initial) = 125 <sup>0</sup> C; V <sub>RM</sub> ≤ 10V	: 1.62 x 10 <sup>6</sup> A <sup>2</sup> s
I <sup>2</sup> t : t = 3ms; T <sub>J</sub> (initial) = 125 <sup>0</sup> C; V <sub>RM</sub> ≤ 10V	: 1.20 x 10 <sup>6</sup> A <sup>2</sup> s
T <sub>HS</sub> : Operating Range	: -40 To +125 <sup>0</sup> C
T <sub>stg</sub> : Non-operating	: -40 To +150 <sup>0</sup> C

**Characteristics**

(Maximum values unless otherwise stated)

$V_o$	: 1.27 V
$r_s$	: 0.420 m $\Omega$
A : $T_J = 25^\circ\text{C}$	:
B : $T_J = 25^\circ\text{C}$	:
C : $T_J = 25^\circ\text{C}$	:
D : $T_J = 25^\circ\text{C}$	:
A )	:
B ) $V_F = A + B.\ln(i_F) + C.i_F + D \sqrt{i_F}$	:
C )	:
D )	:
$V_{FM}$ at $I_{FM} = 2200$ A	: 2.20 V
$R_{th(J-HS)}$ Double side cooled ) Steady-state d.c. and Single side cooled ) 1 $\phi$ a.c. resistive load.	: 0.022 K/W : 0.044 K/W
$I_{RRM}$ : at $V_{RRM(MAX)}$	: 60 mA
$V_{fr}$ : at $di_F/dt =$	: ---
Reverse recovery at $I_{FM} = 1000$ A; $t_p = 1000$ $\mu\text{s}$ $di_R/dt = 60$ A/ $\mu\text{s}$ ; $V_{RM} = 50$ V	
$Q_{RR}$ (total area)	: ---
$Q_{RA}$ (50% chord)	: 810 $\mu\text{C}$
$t_{rr}$ (50% chord)	: 8 $\mu\text{s}$
$I_{RM}$	: ---
Mounting Force	: 19 - 26 kN (1900 - 2600 kg.f)
Outline Drawing	: 100A249
JEDEC Outline No.	: DO-200AC

NOTE: All characteristics are at  $T_{VJ} = T_{Jmax}$  operating unless stated otherwise.

CONTENTS	Page
Ratings	1
Characteristics	2
Contents	3
Voltage Ratings	4
(2) Introduction	5
(3) Notes on the Ratings	
(a) Square wave ratings	5
(b) Energy per pulse characteristics	5
(4) Reverse Recovery Loss	
(a) Determination by measurement	5
(b) Design Method	6
Limit Forward Voltage Characteristic	7
Transient Thermal Impedance Characteristic	8
Surge Current and $I^2t$ vs Duration of Surge	9
Recovered Charge	10
S - Factor	11
Reverse recovery energy per pulse	12
Square wave frequency rating 85 <sup>0</sup> C Sink 500 A/ $\mu$ s	13
Square wave frequency rating 55 <sup>0</sup> C Sink 500 A/ $\mu$ s	14
Square wave frequency rating 85 <sup>0</sup> C Sink 100 A/ $\mu$ s	15
Square wave frequency rating 55 <sup>0</sup> C Sink 100 A/ $\mu$ s	16
Energy per pulse 500 A/ $\mu$ s	17
Energy per pulse 100 A/ $\mu$ s	18
Sine wave frequency rating 85 <sup>0</sup> C Sink	19
Sine wave frequency rating 55 <sup>0</sup> C Sink	20
Sine wave energy per pulse	21
Outline Drawing	22

Changes to Pages 1,2 &3

Page 1 Re-issued: Mean currents  
Page 2 Re-issued: Thermal impedance  
Page 3 Re-issued: Modification list added  
Page 8 Re-issued: New Plot  
Page 22 Re-issued: New O/L Drawing

Voltage Ratings

Voltage Class	$V_{RRM}$ V	$V_{RSM}$ V
26	2600	2700
28	2800	2900
30	3000	3100
32	3200	3300
34	3400	3500
36	3600	3700

This Report is applicable to higher or lower voltage grades when supply has been agreed by Sales/Production.

## 2.0 INTRODUCTION

The diode series comprises fast recovery cold-weld capsules with all diffused silicon slices. All these diodes have controlled reverse recovery characteristics with good "S" factors.

## 3.0 NOTES ON THE RATINGS

### (a) Square wave ratings

These ratings are given for leading edge linear rates of rise of forward current of 100 and 500A/uS.

### (b) Energy per pulse characteristics

These curves enable rapid estimation of device dissipation to be obtained for conditions not covered by the frequency ratings.

Let:  $E_p$  be the Energy per pulse for a given current and pulse width, in joules.

Then  $W_{AV} = E_p \times f$ .

and  $T_{SINK} = T_{J(MAX)} - W_{AV} R_{th}$

## 4.0 REVERSE RECOVERY LOSS

On account of the number of circuit variables affecting reverse recovery voltage, no allowance for reverse recovery loss has been made in these ratings. The following procedure is recommended for use where it is necessary to include reverse recovery loss.

### (a) Determination by Measurement

From waveforms of recovery current obtained from a high frequency shunt (see Note 1) and reverse voltage present during recovery, an instantaneous reverse recovery loss waveform must be constructed. Let the area under this waveform be  $A$  joules per pulse. A new heat sink temperature can then be evaluated from:

$$T_{SINK} \text{ (new)} = T_{SINK} \text{ (original)} - A \left( \frac{r_t \cdot 10^6}{t} + R_{th} \times f \right)$$

where  $r_t = 4.11 \times 10^{-5} \sqrt{t}$

$t$  = duration of reverse recovery loss per pulse in microseconds

$A$  = Area under reverse loss waveform per pulse in joules (W.S.)

$f$  = rated frequency at the original heat sink temperature

The total dissipation is now given by

$$W_{(TOT)} = W_{(original)} + Axf$$

NOTE 1

REVERSE RECOVERY LOSS BY MEASUREMENT

This device has a low reverse recovered charge and peak reverse recovery current. When measuring the charge care must be taken to ensure that:

- (a) a.c. coupled devices such as current transformers are not affected by prior passage of high amplitude forward current.
- (b) The measuring oscilloscope has adequate dynamic range - typically 100 screen heights - to cope with the initial forward current without overload.
- (c) Measurement of reverse recovery voltage waveform should be carried out with an appropriate snubber of .22 uF and 10ohms in series connected across diode anode to cathode.

(b) Design Method

In circumstances where it is not possible to measure voltage and current conditions, or for design purposes, the additional losses may be estimated from curves on page 12

Let E be the value of energy per reverse cycle in joules (curves on page 12)

Let f be the operating frequency in Hz

$$\text{Then } T_{\text{SINK}}^{(\text{new})} = T_{\text{SINK}}^{(\text{original})} - E \times R_{\text{th}} \times f$$

Where  $T_{\text{SINK}}^{\text{new}}$  is the required maximum heat sink temperature and  $T_{\text{SINK}}^{\text{original}}$  is the heat sink temperature given with the frequency ratings.

824.15

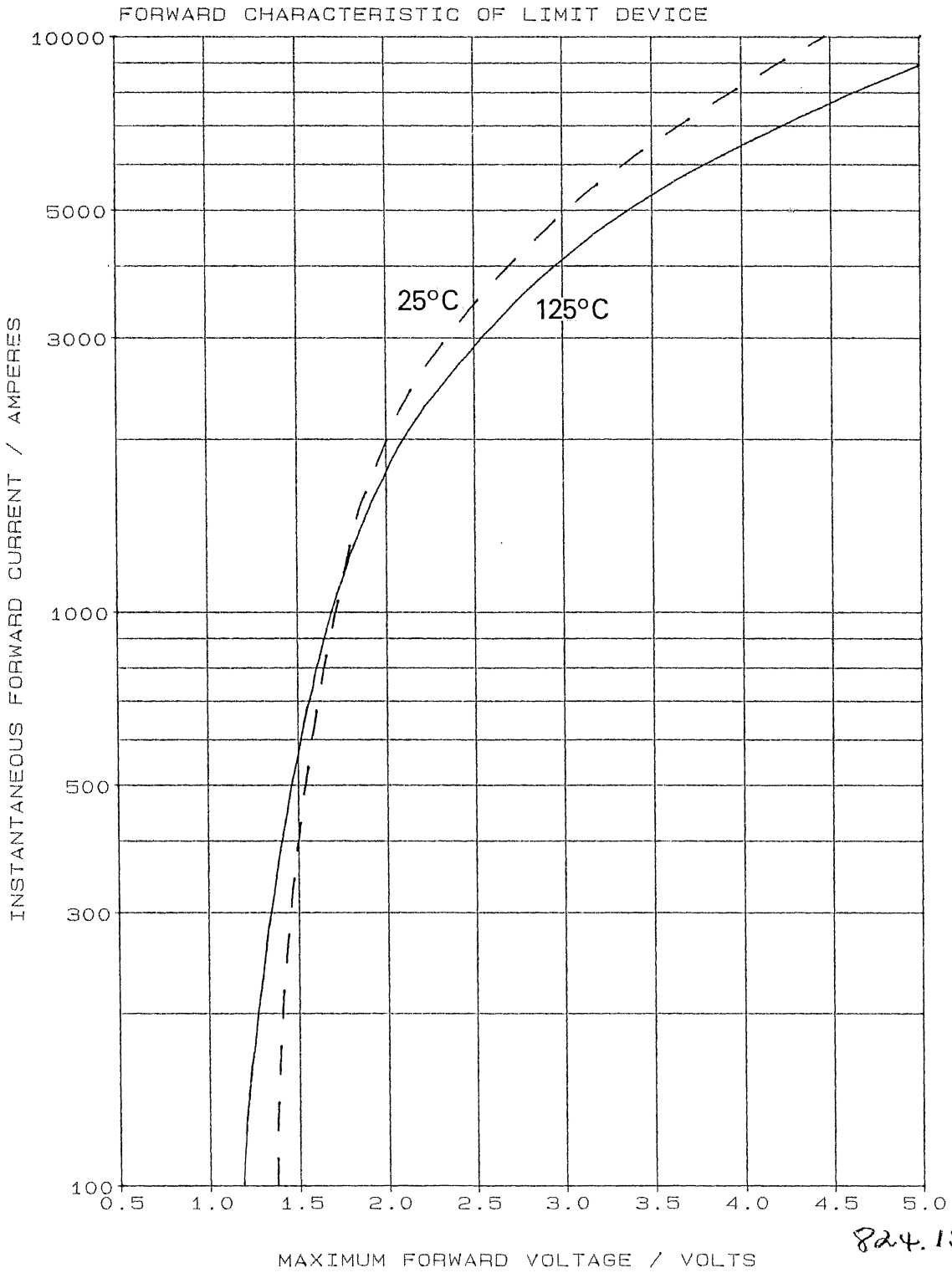

# Transient Thermal Impedance (Junction to Heat Sink)

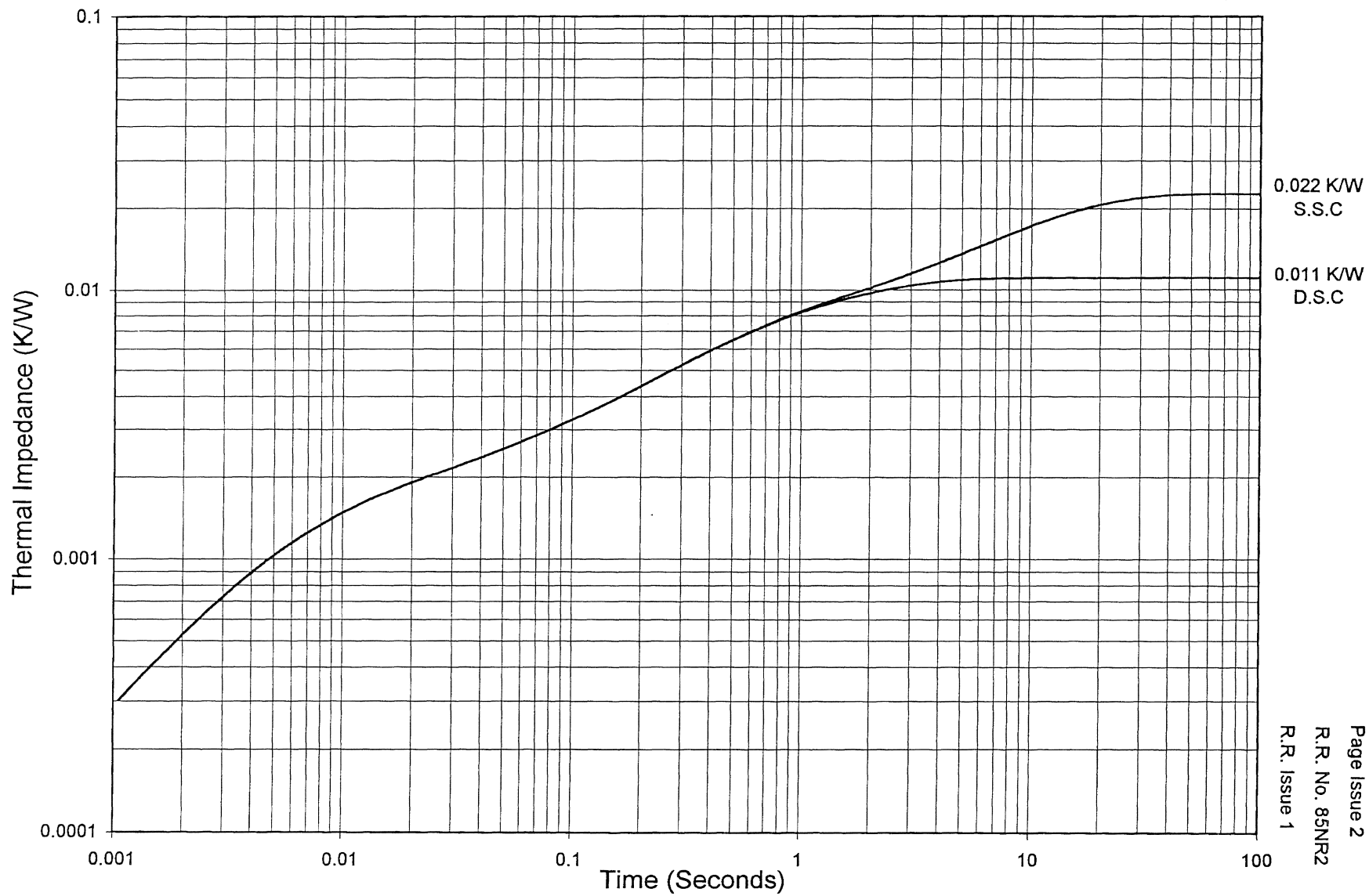

0.022 K/W  
S.S.C

0.011 K/W  
D.S.C

MAXIMUM NON REPETITIVE SURGE CURRENT AT INITIAL JUNCTION TEMPERATURE 125°C

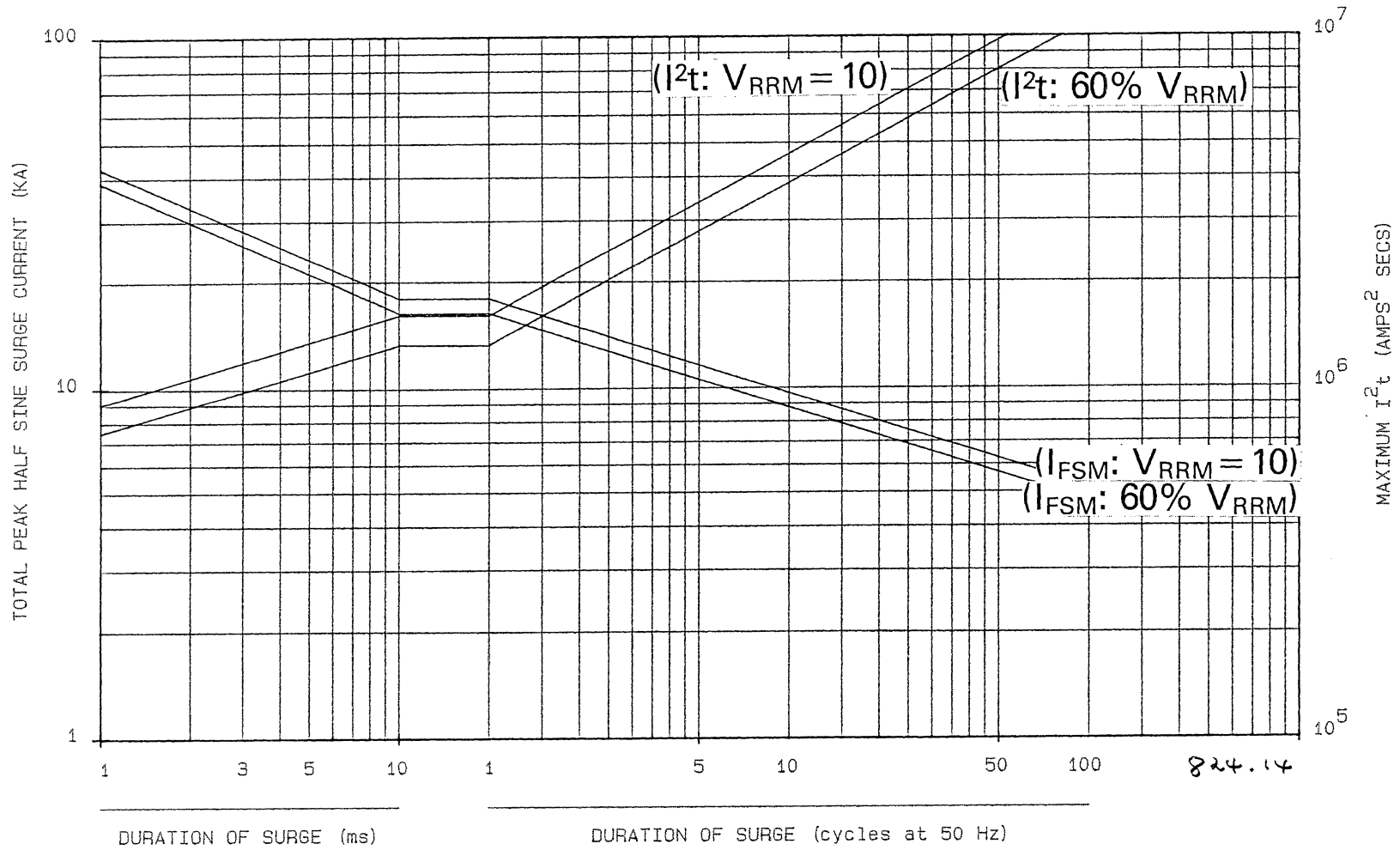

Handwritten notes: 7131, 14, 1768

MAXIMUM RECOVERED CHARGE AT 125°C JUNCTION TEMPERATURE

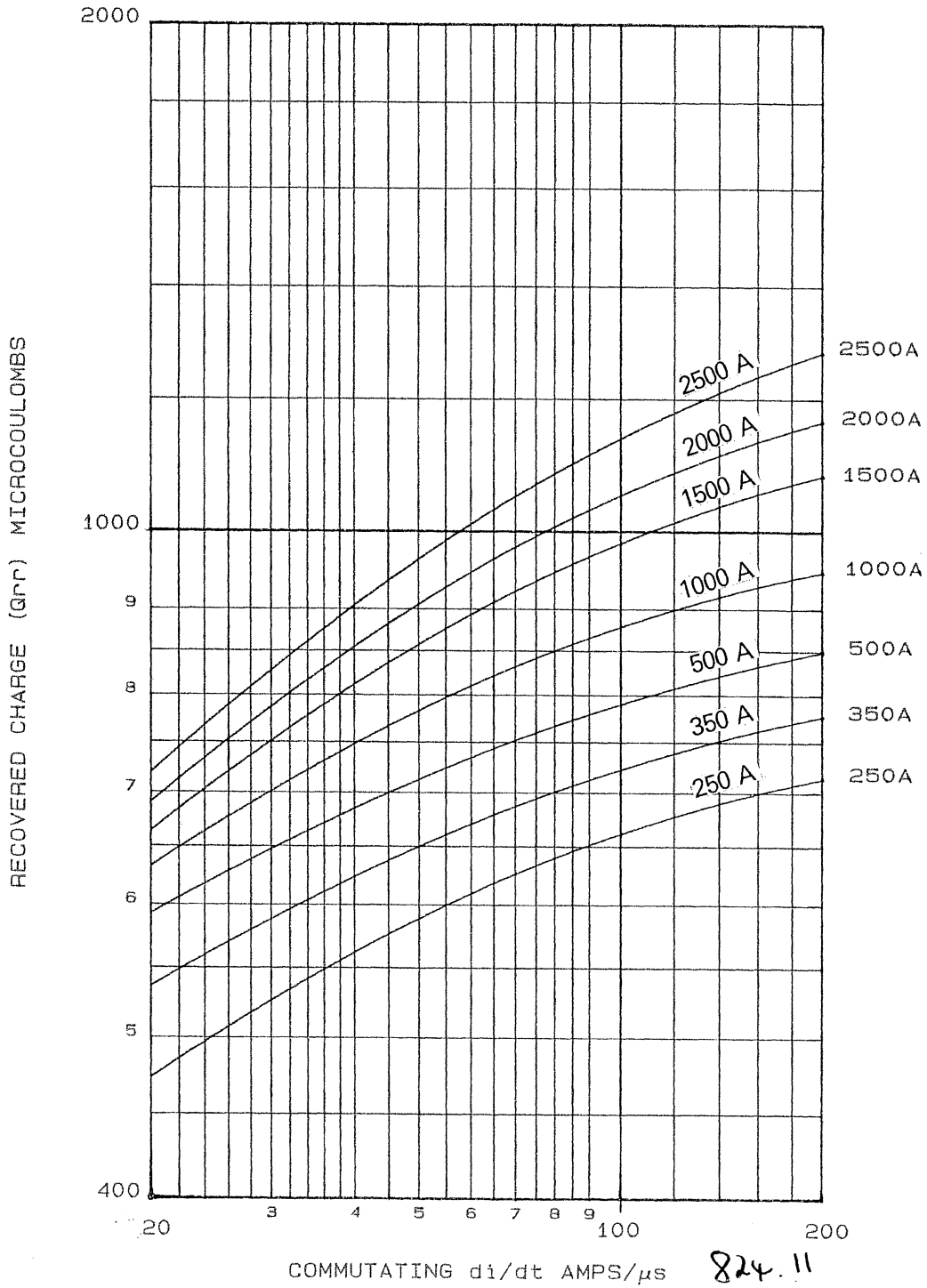

MINIMUM S FACTOR AT 125°C JUNCTION TEMPERATURE

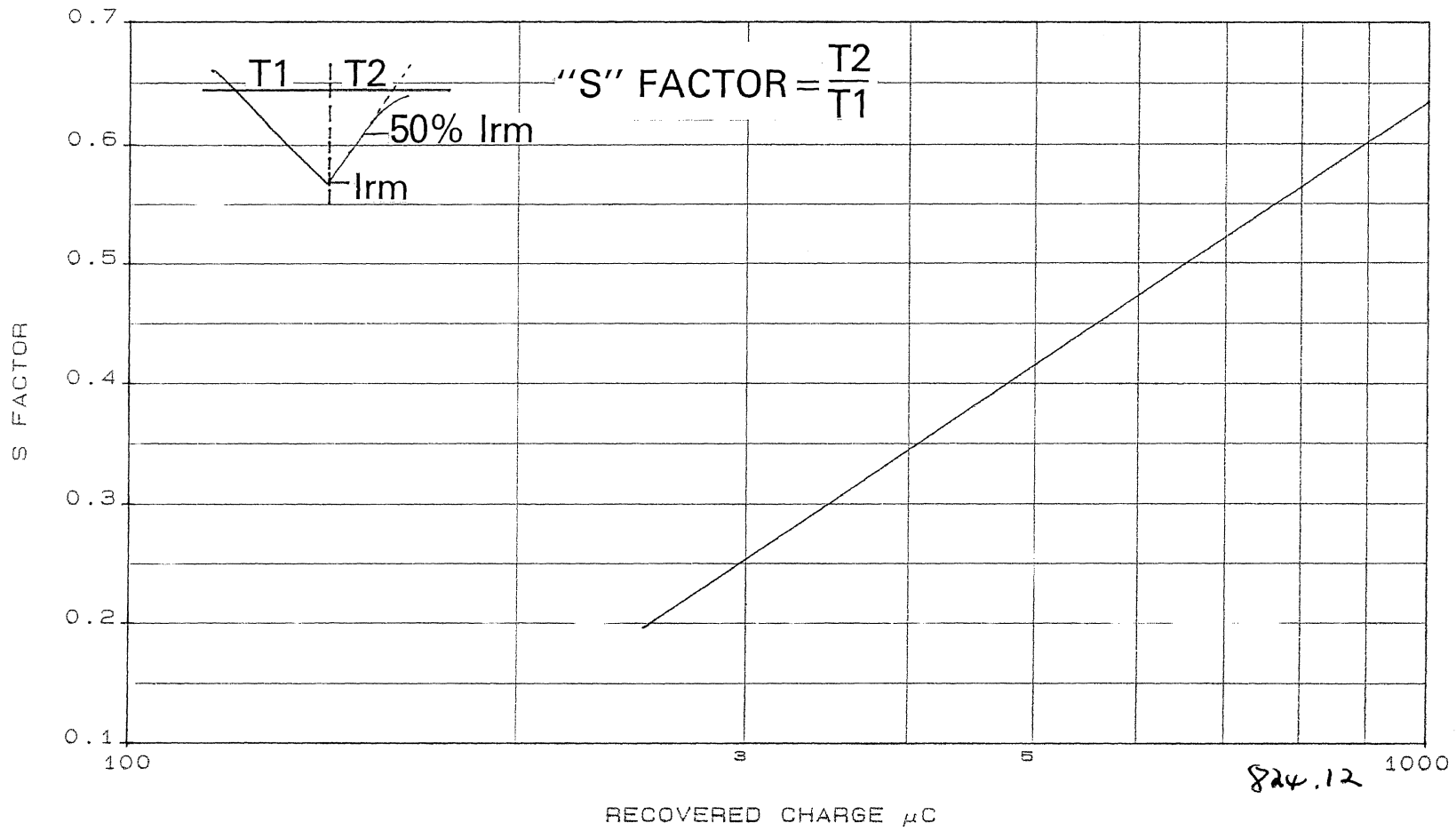

MAXIMUM REVERSE RECOVERY ENERGY LOSS PER PULSE, 125°C JUNCTION TEMPERATURE

SNUBBER CONNECTED 0.22μF, 10 OHMS  
 PEAK REVERSE VOLTAGE  $V_{RM} = 0.67$  OF HIGHEST GRADE VOLTAGE\*

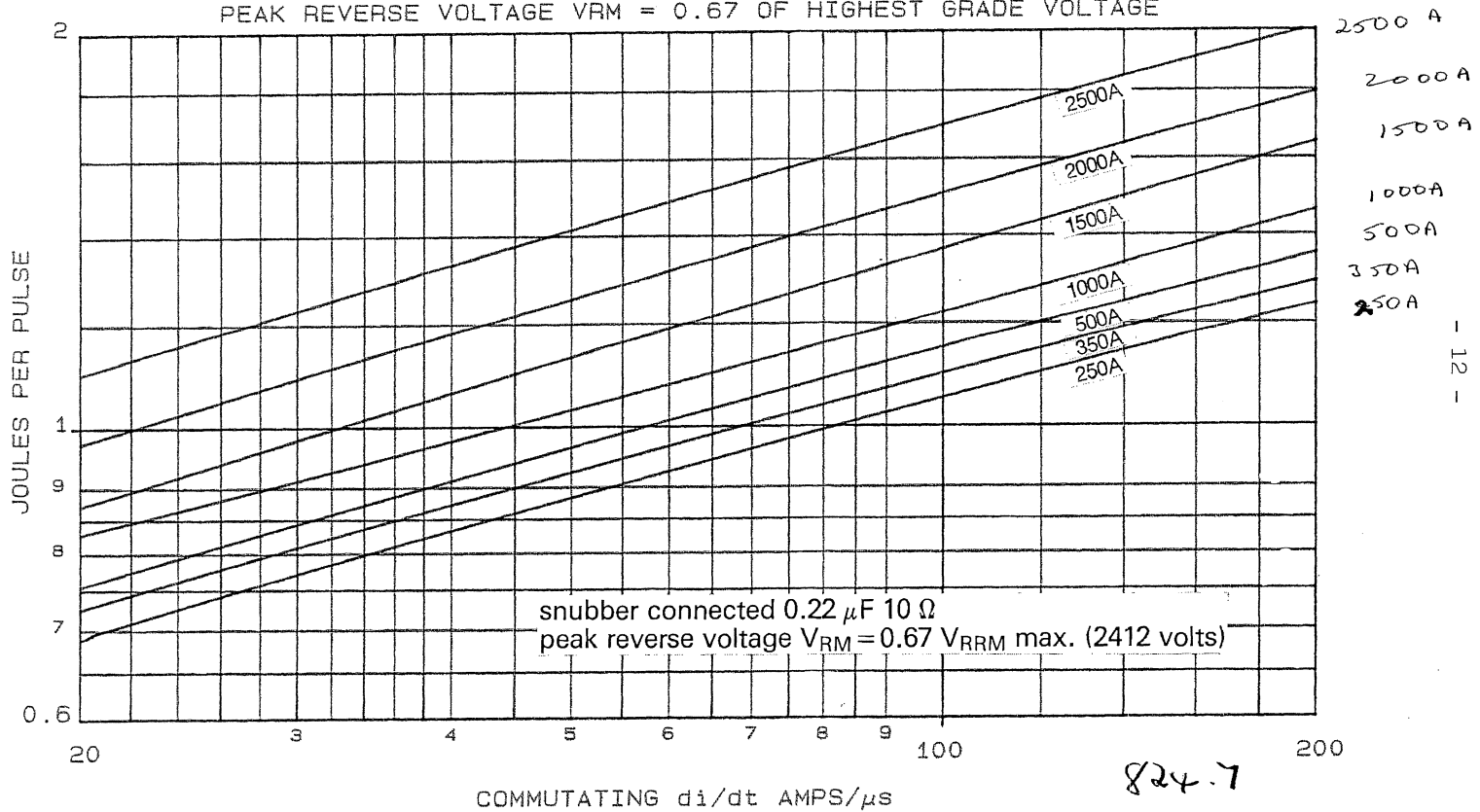

\* NOTE: ENERGY PER PULSE SHOULD BE ADJUSTED PRO RATA WITH APPLIED PEAK RECOVERY VOLTAGE

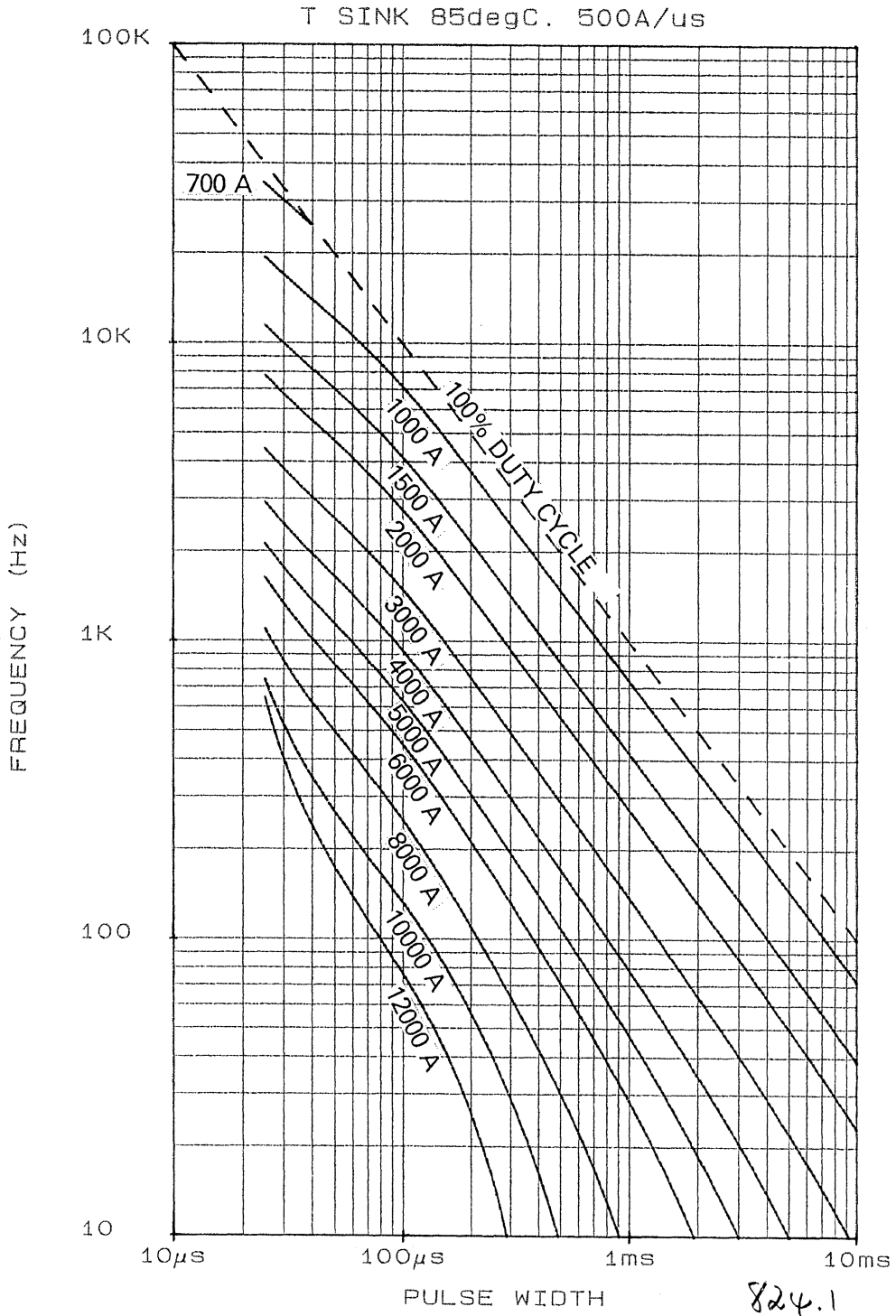

8-1

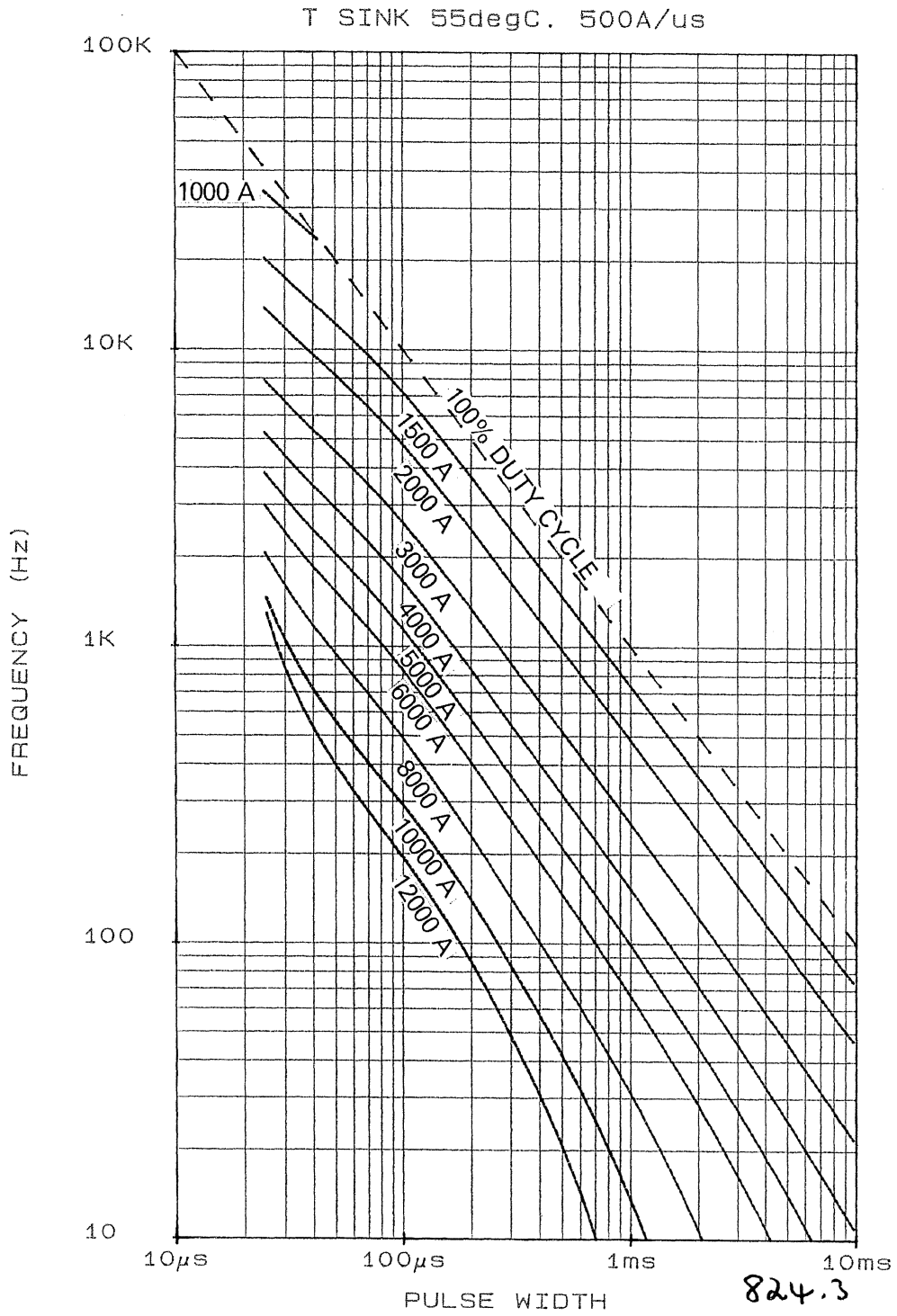

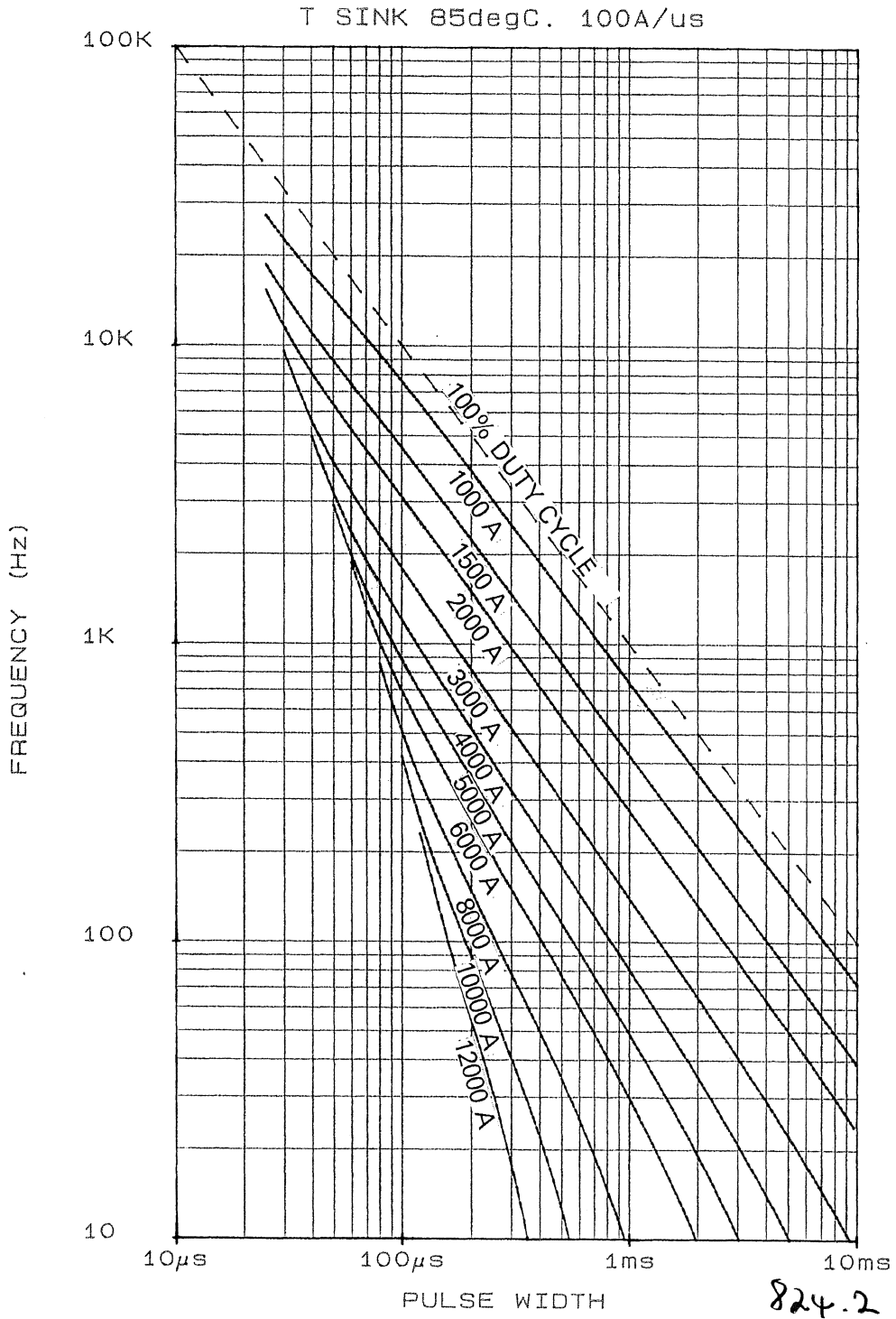

T SINK 55degC. 100A/us

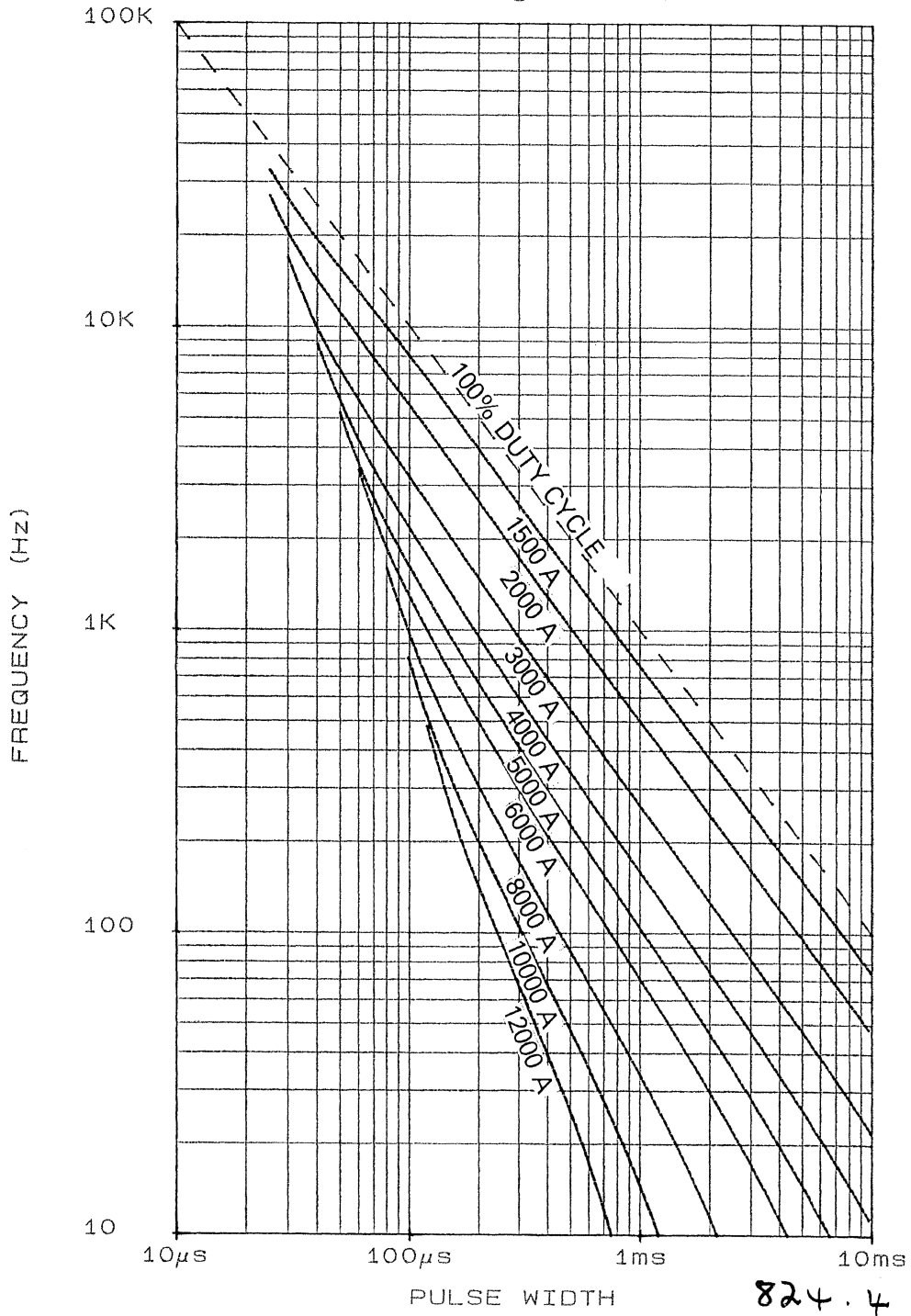

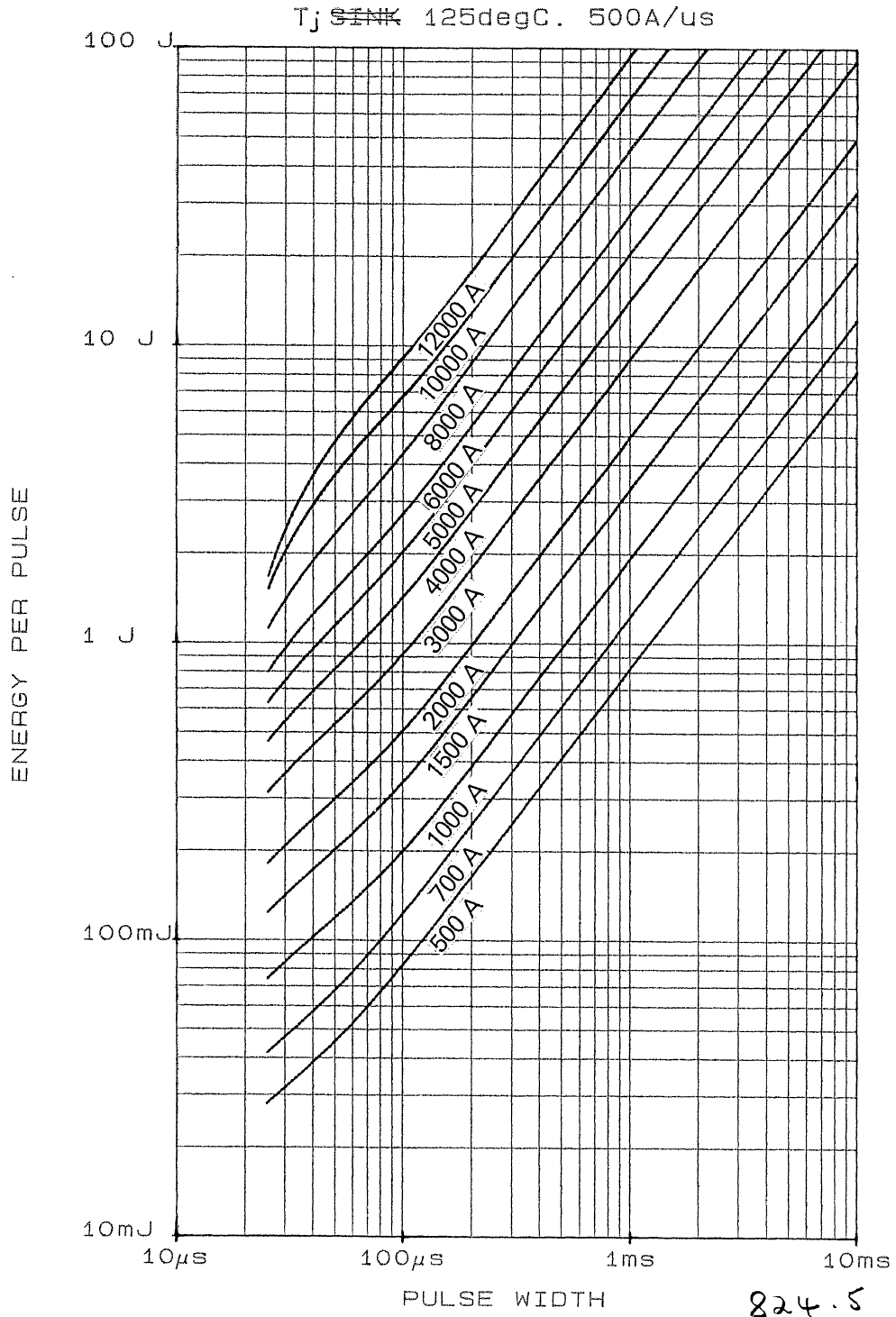

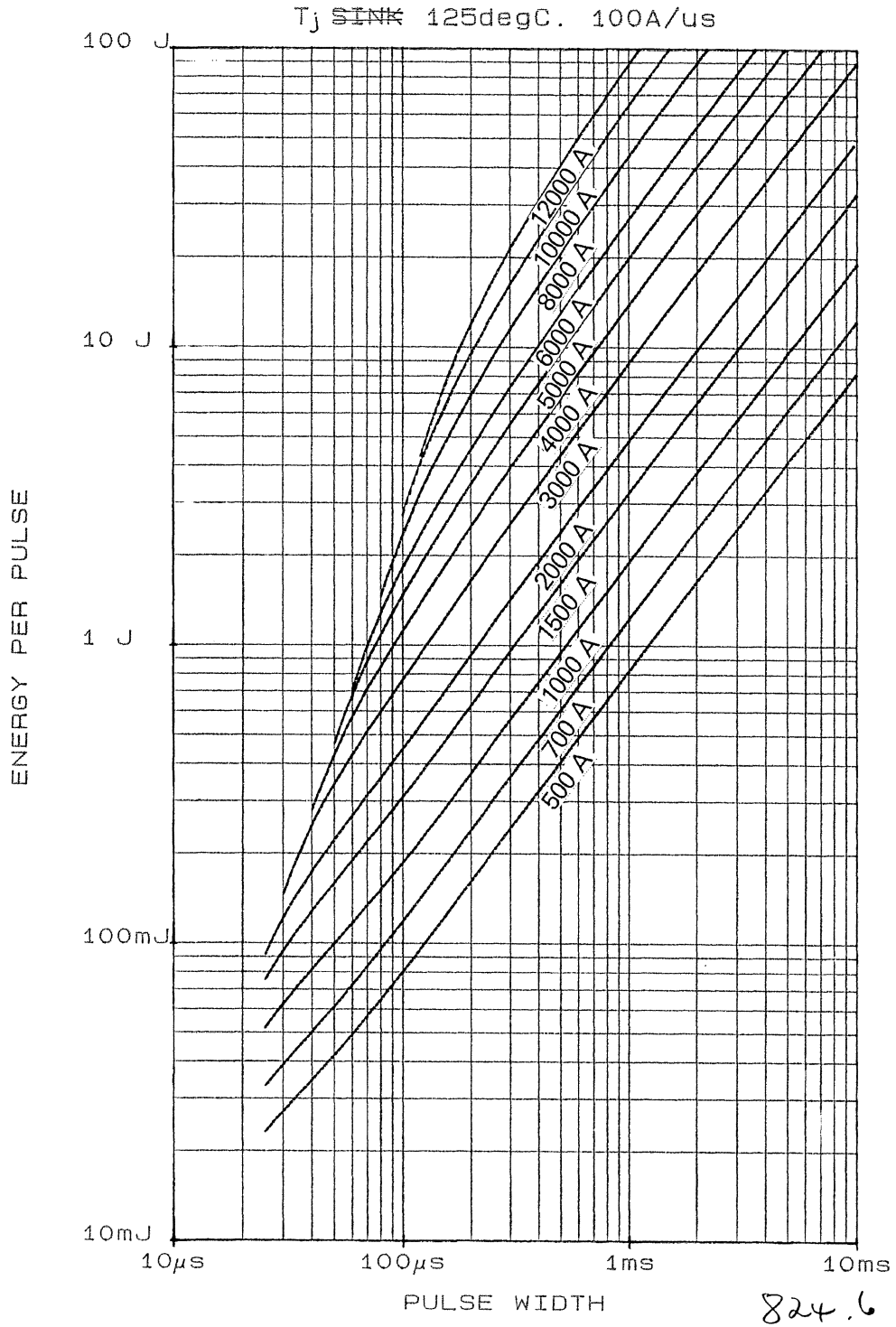

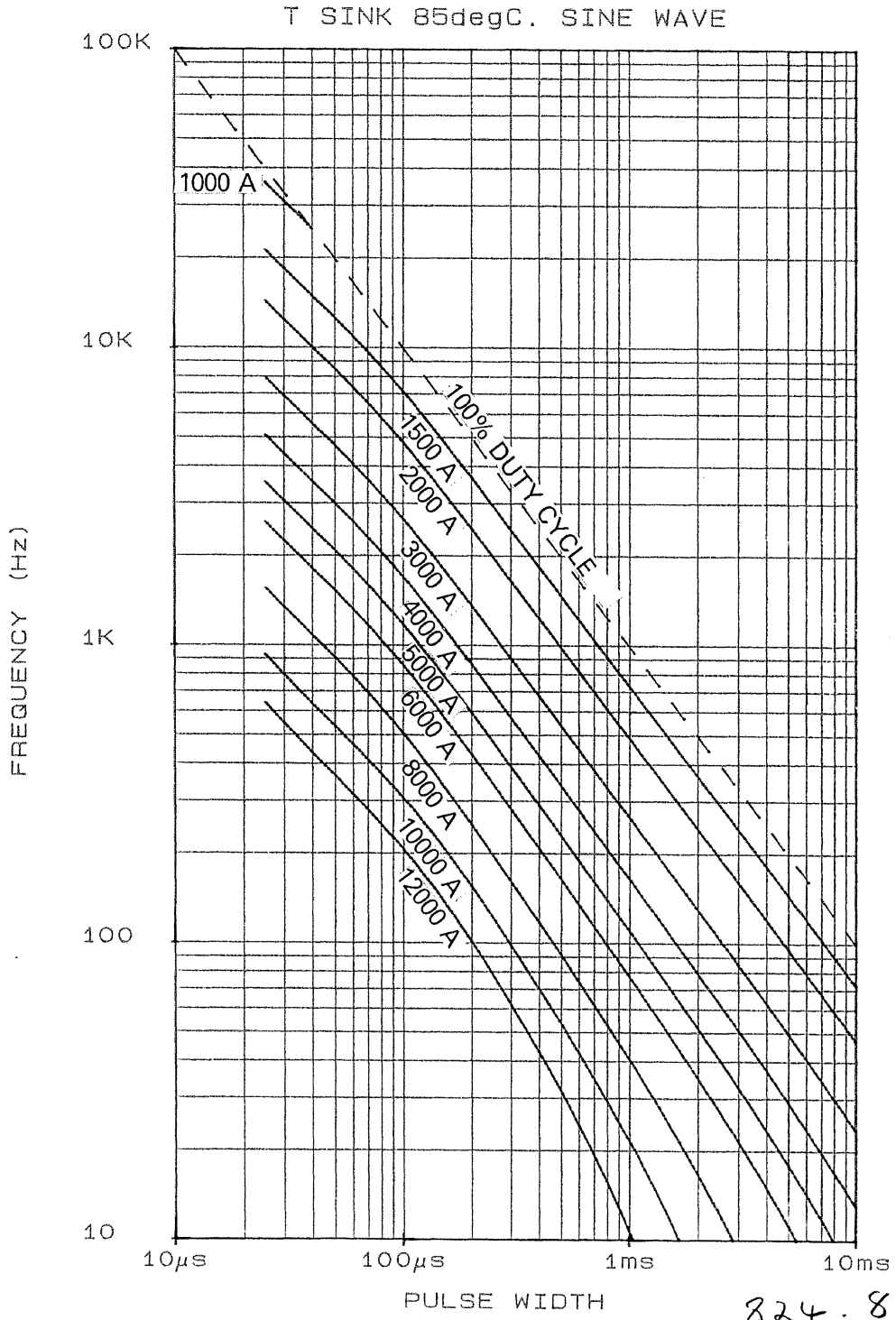

824 5.10

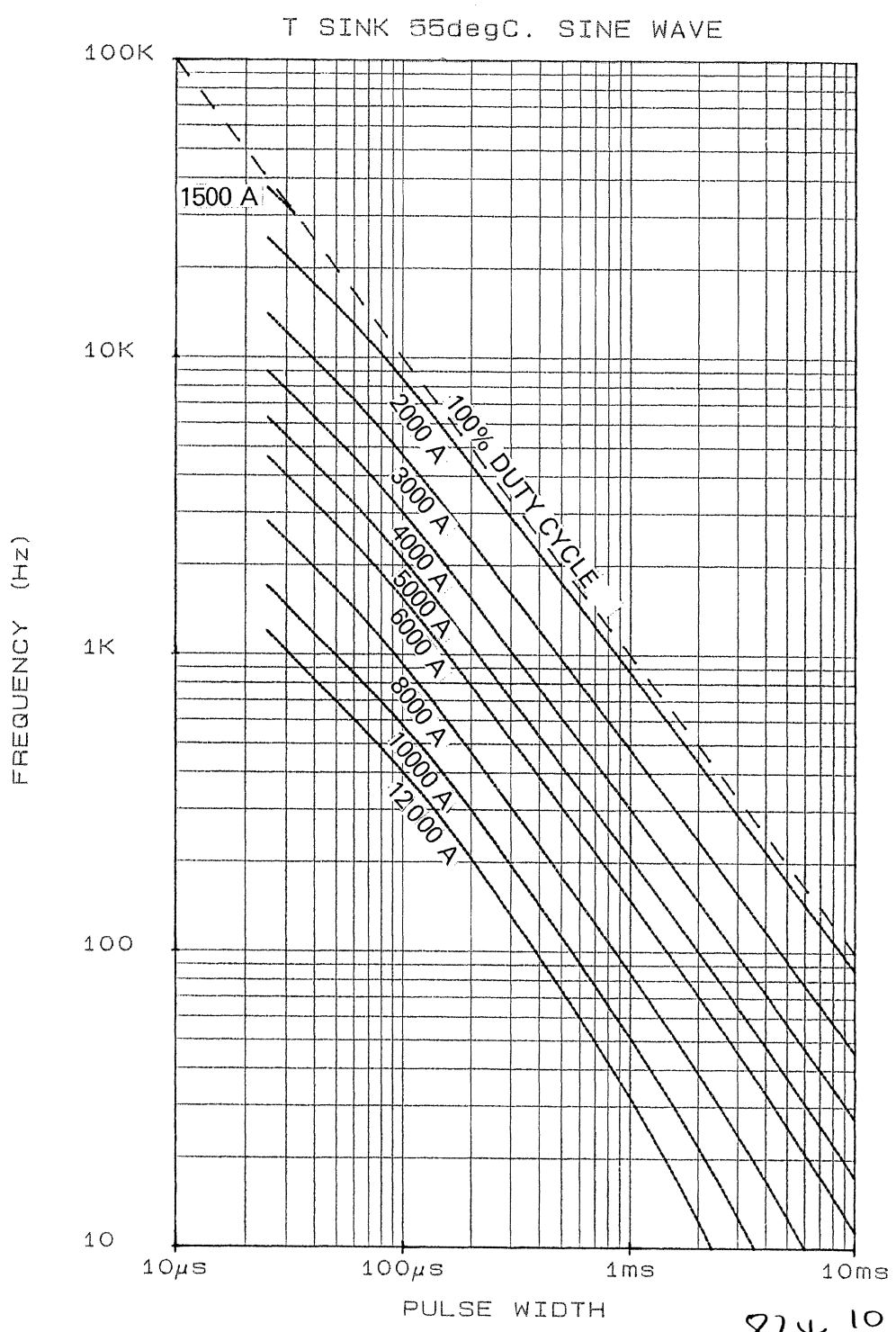

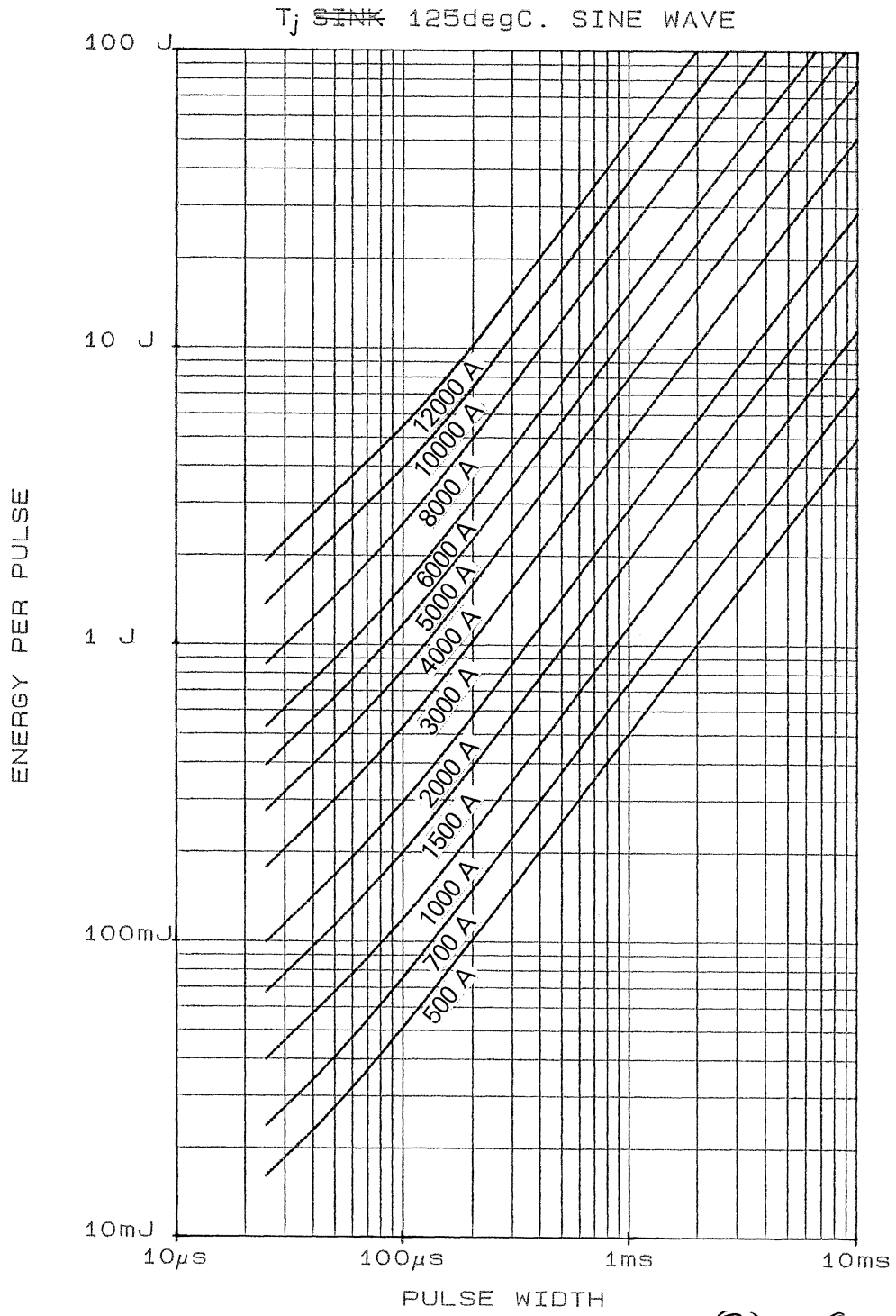

824.9

SCALE	1/1
DRN	<i>[Signature]</i>
CHKD	<i>[Signature]</i>
APPD	
	688-1
	CS 1
	GA 1
	LP 2
	HP 2
	6
S	NI

INTERNATIONAL OUTLINE No. **DO-200AC**  
 WEIGHT. **510 GRAMS.**  
 FINISH. **NICKEL PLATE.**  
 DEVICE MARKING INCLUDES MONOGRAM, TYPE No., SPEC. No. AND POLARITY SYMBOL.

TYPE NUMBER	
CXC 680	CXC 924
CXC 820	CXC 624
CXC 950	CXC 824
CXC 14C	
CXC 990	
CXC 850	

DEVICE MOUNTING: CLAMPING FORCE TO BE APPLIED ON  $\phi$  OF LOCATION HOLES AND BE EVENLY DISTRIBUTED OVER AREA OF CONTACT. FLAT TOL ON SURFACES TO WHICH DEVICE IS CLAMPED TO BE 0.04 WIDE.  
 CLAMPING FORCE 1900 - 2600 kgf.

G.A. DRG. No. 159B100H301 - H310

$\phi$  3.6/3.5 x 3 MIN DEPTH  
 2-HOLES. ONE IN CATHODE  
 AND ONE IN ANODE.

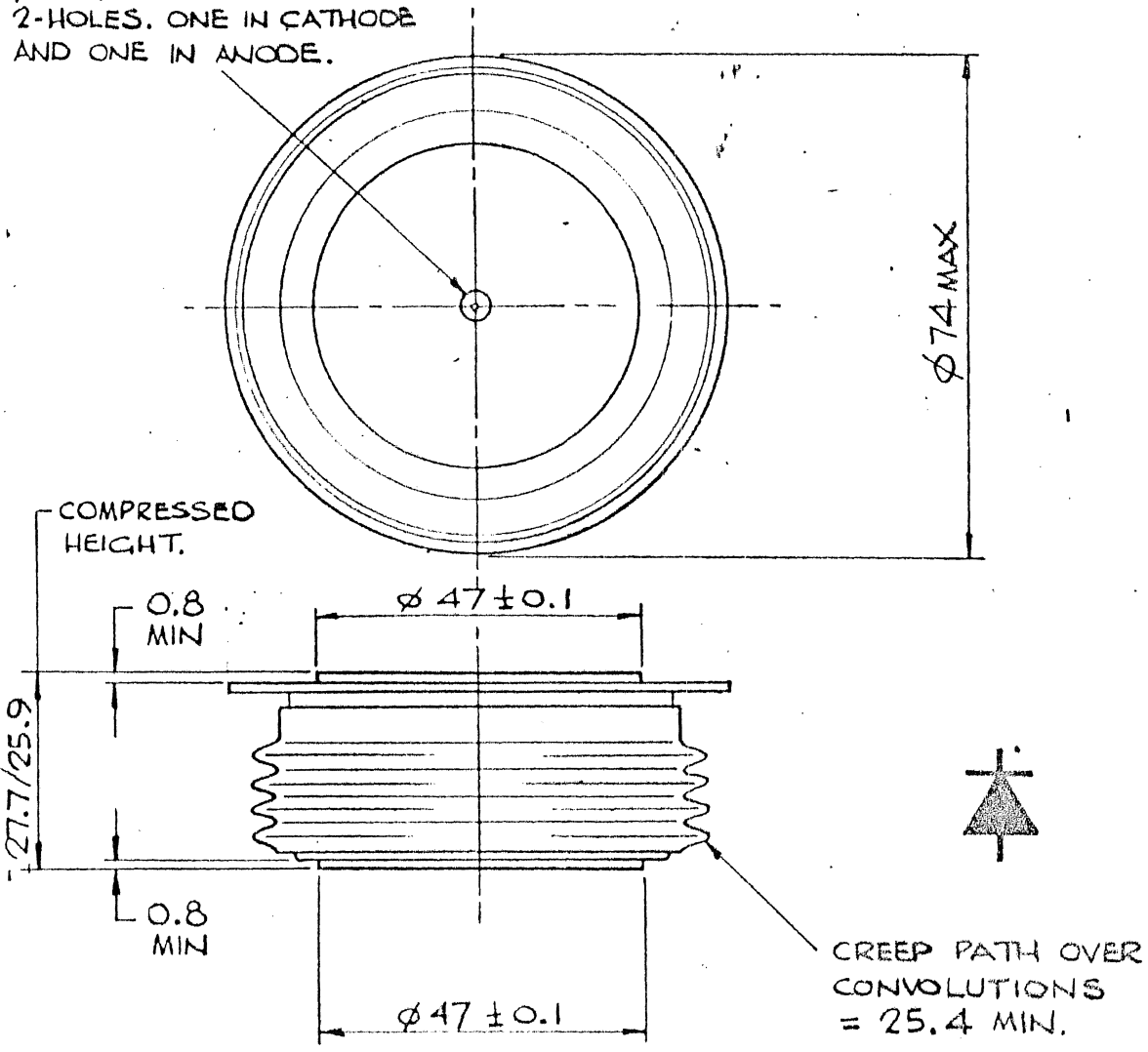

THE INFORMATION CONTAINED IN THIS DRAWING IS SUPPLIED IN CONFIDENCE AND IS PROTECTED BY COPYRIGHT. THE INFORMATION MAY NOT BE DISCLOSED EXCEPT WITH THE WRITTEN PERMISSION OF AND IN MANNER PERMITTED BY THE PROPRIETORS. WESTINGHOUSE BRAKE AND SIGNAL CO. LTD.

WESTINGHOUSE BRAKE AND SIGNAL CO. LTD.  
 CHIPPENHAM, WILTSHIRE, SN15 1JD, ENGLAND.

 WESTCODE<sup>®</sup>  
 SEMICONDUCTORS

THIRD ANGLE PROJECTION

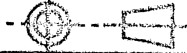

DIMNS. IN MILLIMETRES

DRG. No.  
**100A 249**

ISS	REVISIONS
1	15.5.78 P304
2	12.9.78 $\phi 74$ WAS 1 $\phi 75$ k
3	30.10.78 M670 TYPE N° ADDED/16

**Drawing Number – W5**  
**Outline Number – 100A249**

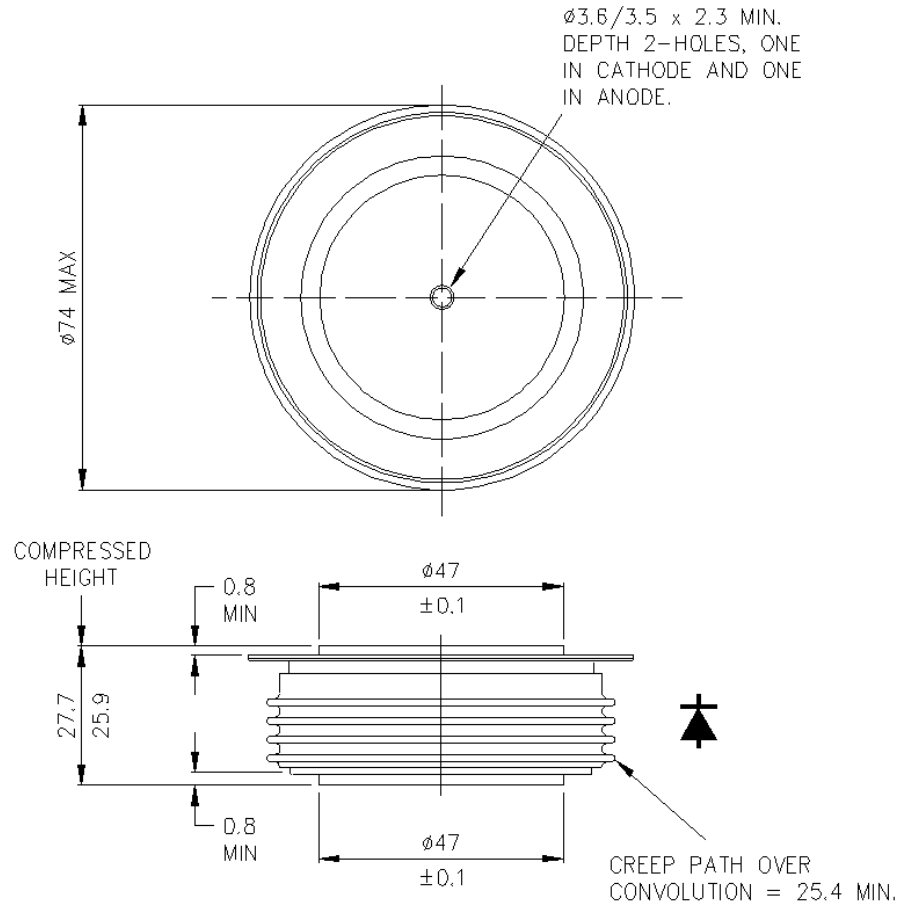

Not recommended for new designs

**Weight 510g**